

PROPOSED PLAN OF G+III STORED RESIDENTIAL BUILDING OF 12.50 M. HEIGHT U/S 393 (A) OF K.M.C. ACT 1980, ALONG WITH BUILDING RULE 2009, AT K.M.C. PREMISES NO. - 11C, HEM CHANDRA MUKHERJEE ROAD, WARD NO. - 123, BOROUGH NO. - XVI, WITHIN THE LIMITS OF THE KOLKATA MUNICIPAL CORPORATION

OWNERS :- 1) SRI BAPI CHAKRABORTY, 2) SRI ARUN GHOSH, 3) SRI SAJAL GHOSH & 4) SRI ABHIJIT GHOSH

AREA STATEMENT OF THE PLAN PROPOSAL

1. ASSESSEE NO. - 41-123-07-0060-0
2. DETAILS OF REGISTERED DEED -
PAGE - 287964 TO 287978, BEING NO. - 160709105,
DATE - 04/07/2022,
REGD. AT - A.D.S.R. BEHALA, W.B.
3. DETAILS OF REGISTERED BOUNDARY DECLARATION -
PAGE - 16444 TO 16449, BEING NO. - 160700088,
DATE - 10/01/2023,
REGD. AT - A.D.S.R. BEHALA, W.B.
4. DETAILS OF REGISTERED CORNER GIFT -
BOOK NO. - I, VOLUME - 1607/2023,
PAGE - 10/01/2023,
REGD. AT - A.D.S.R. BEHALA, W.B.
5. DETAILS OF REGISTERED POWER OF ATTORNEY -
BOOK NO. - I, VOLUME - 1607/2023,
PAGE - 09/12/2022,
REGD. AT - A.D.S.R. BEHALA, W.B.
6. DETAILS OF REGISTERED NON-FUNCTION OF TENANT -
PAGE - 38431 TO 38444, BEING NO. - 160700803,
DATE - 03/02/2023,
REGD. AT - A.D.S.R. BEHALA, W.B.
7. AREA OF LAND -
a) AS PAR DEED = 6 K - 05 CH. - 24 SFT = 424.470 SQM.
b) AS PAR B. / D. = 422.078 SQM.
8. SIZE OF TENAMENTS -
50 SQM ABOVE & 75 SQM. BELOW = 14 (FOURTEEN) NOS.
9. NO. OF STORED - G + III

DECLARATION OF OWNER / S
I DO HEREBY DECLARE WITH FULL RESPONSIBILITY THAT WE SHALL ENGAGE L.B.S. & E.S.E. DURING CONSTRUCTION OF THE BUILDING (AS PER B.S. PLAN).
KMC AUTHORITY WILL NOT BE RESPONSIBLE FOR STRUCTURAL STABILITY OF THE BUILDING AND ADJOINING BUILDINGS TO BE BUILT. THE AUTHORITY WILL BE RESPONSIBLE TO BE KEPT AS IS.
THE CONSTRUCTION OF SEMI UNDERGROUND WATER RESERVOIR AND SEPTIC TANK WILL BE UNDERTAKEN UNDER THE GUIDANCE OF E.S.E. / L.B.S. BEFORE STARTING OF BUILDING FOUNDATION WORK.
DURING INSPECTION I WAS PRESENT AT SITE.
ALL FLOORS WILL BE OF MARBLE FINISH.

DECLARATION OF L.B.S.
CERTIFIED WITH FULL RESPONSIBILITY THAT THE BUILDING PLAN HAS BEEN DRAWN UP AS PER PROVISION OF KMC & BUILDING RULES 2009. THE CONSTRUCTION OF THE BUILDING SHALL BE IN ACCORDANCE WITH THE CONDITIONS INCLUDING THE WIDTH OF ABUTTING K.M.C. MAINTAINED ROAD CONFORMS WITH THE PLAN, WHICH HAS BEEN MEASURED AND VERIFIED BY ME.
IT IS A BUILDABLE SITE NOT A TANK OR FILLED UP TANK THE CONSTRUCTION OF S.U.G. WATER RESERVOIR AND SEPTIC TANK WILL BE COMPLETED BEFORE STARTING OF BUILDING FOUNDATION WORK.

NAME OF L.B.S.
SOURAV MUKHERJEE
L.B.S. NO. - LBS/11/1122

NAME OF APPLICANT(S)
M/S LOKENATH CONSTRUCTION REPRESENTED BY ITS PARTNERS 1) SRI ARUN GHOSH, 2) SRI BAPI CHAKRABORTY & SAMANTA, 3) SRI SAJAL GHOSH, C.A. OF 1) SRI BAPI CHAKRABORTY, 2) SRI ARUN GHOSH, CHAKRABORTY, 3) SRI SAJAL GHOSH & 4) SRI ABHIJIT GHOSH

**B.P. NO. - 2023160053... DATE - 10.05.2023...
VALID UPTO - 09.05.2028...**

DIGITAL SIGNATURE OF A.E.
SANJIT MAJI
Digitally signed by SANJIT MAJI
Date: 2023.05.11 14:08:05+05'30'

DIGITAL SIGNATURE OF E.E.
SHIBNATH DAS
Digitally signed by SHIBNATH DAS
Date: 2023.05.11 15:33:40+05'30'

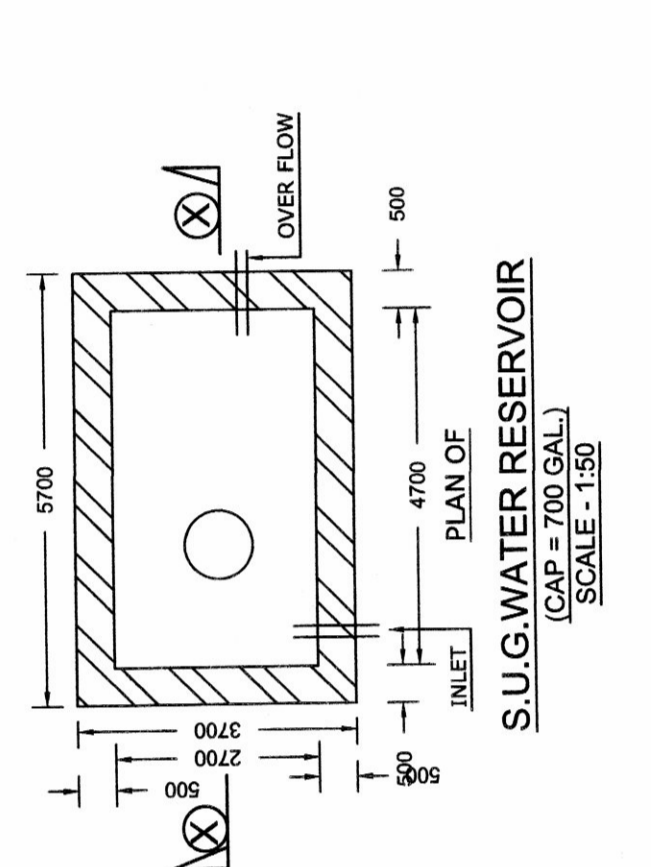
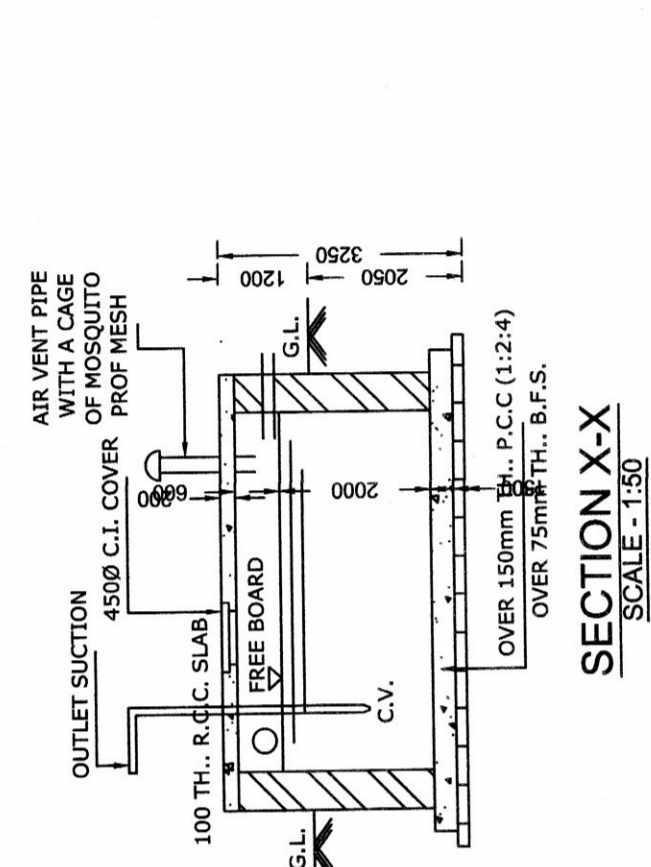

Premises No. : 11C, Hem Chandra Mukherjee Road
WARD - 131
ASSESSEE NO - 41-123-07-0060-0
NAME OF THE OWNER - M/S Lokenath Construction, Partners
1) Sri Arun Sinha, 2) Sri Samit Samanta,
3) Sri Bapi Chakraborty & 4) Sri Arun Ghosh, C.A. of 1) Sri Bapi Chakraborty,
2) Sri Arun Ghosh, 3) Sri Sajal Ghosh,
& 4) Sri Abhijit Ghosh

LAND AREA - 422.078 SQM.
NAME OF THE L.B.S. - SOURAV MUKHERJEE
PERMISSIBLE HEIGHT IN REFERENCE TO CCZM ISSUED BY AA1 - 48.32 MTS.

CO-ORDINATION IN WGS 84 AND SITE ELEVATION (AMSL) :

REFERENCE POINTS MARKED IN THE SITE PLAN OF THE PROPOSAL	CO-ORDINATION IN WGS 84	SITE ELEVATION (AMSL)
Latitude	Longitude	
POINT - A'	22°29'1.69"N 88°19'15.62"E	4.26 M
POINT - A"	22°29'1.90"N 88°19'14.59"E	
POINT - A'''	22°29'2.19"N 88°19'14.77"E	
POINT - A''''	22°29'2.21"N 88°19'14.91"E	

DECLARATION OF L.B.S.
M/S LOKENATH CONSTRUCTION, 1) SRI ARUN GHOSH, 2) SRI BAPI CHAKRABORTY & SAMANTA, 3) SRI SAJAL GHOSH, C.A. OF 1) SRI BAPI CHAKRABORTY, 2) SRI ARUN GHOSH, CHAKRABORTY, 3) SRI SAJAL GHOSH & 4) SRI ABHIJIT GHOSH

NAME OF L.B.S.
SOURAV MUKHERJEE
L.B.S. NO. - /11/122

DOORS & WINDOWS SCHEDULE		
MKD	WIDTH	HEIGHT
D1	1050	2100
D2	900	2100
D3	750	2100

WINDOW SCHEDULE		
MKD	WIDTH	HEIGHT
W1	1500	1200
W2	1200	1200
W3	1000	1200
W4	800	1200
W5	1000	750

DECLARATION OF GEO-TECHNICAL ENGINEER
UNDERSIGNED HAS INSPECTED THE SITE & CARRIED OUT THE SOIL INVESTIGATION THEREIN. IT IS CERTIFIED THAT EXISTING SOIL OF THE PROPOSED CONSTRUCTION AND THE FOUNDATION SYSTEM THEREIN IS SAFE & STABLE IN ALL RESPECT FROM GEO-TECHNICAL POINT OF VIEW.

DECLARATION OF E.S.E.
THE STRUCTURAL DESIGN AND DRAWING OF BOTH FOUNDATION AND SUPER STRUCTURE OF THE BUILDING HAS BEEN MADE BY ME ON THE BASIS OF SOIL TEST REPORT CONDUCTED BY SOIL TESTING LABORATORY SIGNED BY BHASKAR ROY CONSIDERING OF ALL POSSIBLE LOADS INCLUDING SEISMIC LOAD AS PER NATIONAL BUILDING CODE OF INDIA AND CERTIFIED THAT IT IS SAFE AND STABLE IN ALL RESPECT.

NAME OF G.T.E.
BHASKAR ROY
G.T.E. NO. - GTE/III/2

NAME OF E.S.E.
PRANAB KUMAR DAS
E.S.E. NO. - ESE/11/131

